

Dynisco IoT Cloud Connect via Edge Device



Where Aggregation of Data Enables Insights



Features & Benefits

Production Benefits:

- One place to store, manage and correlate all rheological and sensing data
- Ability to export instruments data into easily managed excel format
- Improved labor/equipment utilization metrics across lines and/or facilities
- Predictive maintenance
- 24/7 lot to lot production correlation to lab measurements

Systematic Benefits:

- Backward compatible to Dynisco legacy products
- Ability to conduct Round Robins between facilities and production lines
- Compares results from:
 - Lab to lab
 - Machine to machine
 - Operator to operator

Description

Integrate and aggregate data from existing Dynisco products such as our LMI5000 & LMI4004 melt flow indexers, our LCR7000 capillary rheometer, and instrumentation like our UPR900 process indicator via the Dynisco Edge Device. With the Edge Device you have a single board computer that helps you better understand and manage:

- Control strategies that adjust the process to improve material quality
- Material verification at each stage of the process using correlations
- Variations in the properties of plastic that affect product quality
- Environmental conditions that lead to variations in test or production process

With the new Dynisco Cloud Connect through Microsoft® Azure— you get a single cloud solution that aggregates all your device(s) data into one place that is secure, reliable, easy to share, with support that is accessible 24/7/365. The Dynisco Cloud Connect also allows for the archival of sample data and displays the information in simple to understand graphs.

The Dynisco Cloud Connect can be used for one product or entire global production lines – whether across the street, or across the globe giving you easy access to manage data across the cloud, no matter where it lives (one subscription per device). This solution is easily expandable, allowing new equipment to be added and is even compatible with multiple types of equipment from sensors to melt flow indexers to rheometers. Compare and correlate data between facilities and be able to monitor parameters in real time, from a mobile device anywhere in the world, whether working in the field, on the production floor, or in the office. This is more than a digital transformation- its the ability to provide a window into your process with insights from yesterday, turning them into better decisions for today and tomorrow.

Why Use the Cloud?

- **Always-on availability:** Microsoft Azure® is extremely reliable and information is available just about anywhere (as long as an a connection to the Internet is possible.)
- **Improved mobility:** Data and applications are available to employees no matter where they are. Users can access critical information anywhere through mobile devices—working in the field, at home, or in the office. This helps create a better work-life balance.
- **Easier to share information:** Collaboration is improved by allowing distributed groups of people to share information in real time.
- **Better control of access to information:** Everyone accesses a single copy of the source information, so you don't have multiple versions of the same file floating around. Access to that information can be controlled - You never know what might happen if information gets into the wrong hands, even if it's just the hands of an untrained employee.
- **Fresh software:** The latest versions of the applications that run the device and leverage the information it generates are made available to all as they're released. Upgrades will put new features and functionality into user's hands faster making them more productive.

Access your information 24/7/365 whether via computer, mobile phone, or tablet

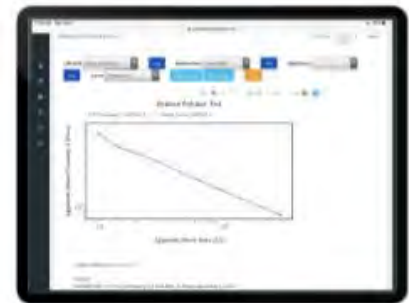

What can I do with this Information?

- Verify the material at each stage of the process
- Ensures product quality is not impacted by variations in material properties
- Allow the processor to adjust parameters based on actual rheological property review



Correlate your rheological data from the lab to the production floor.

Please Note: You must also purchase the respective Dynisco Cloud Connect Subscription for each device for full functionality and access to your data. Please refer to the below table to determine the Edge Device Ordering Code with respective Cloud Connect Subscription Code

Edge Device Ordering Guide: with Corresponding Cloud Connect Subscription Code

Edge Device Ordering Code	Product	Cloud Connect Subscription Code
EDGE_USB	Edge Device for LMI5000	IOT365_LAB_A_1_X*
EDGE_SERIAL_4	Edge Device for LMI4004	
EDGE_SERIAL_O	Edge Device for Online Rheological Testing Equipment (ViscoSensor, CMR, FCR)	IOT365_ONL_X**_1
EDGE_MOD	Edge Device for UP900 Panel Indicator	

1X= the number of units you are purchasing subscriptions for.

Refer to ordering chart on page 5 to replace "X" with the letter that reflects your "Number of Units"

***X= the service level offering you are selecting*

Refer to ordering chart on page 5 to replace "X" with the letter that reflects your desired "Service Level"

Ordering Guide: For Dynisco Cloud Connect Subscription

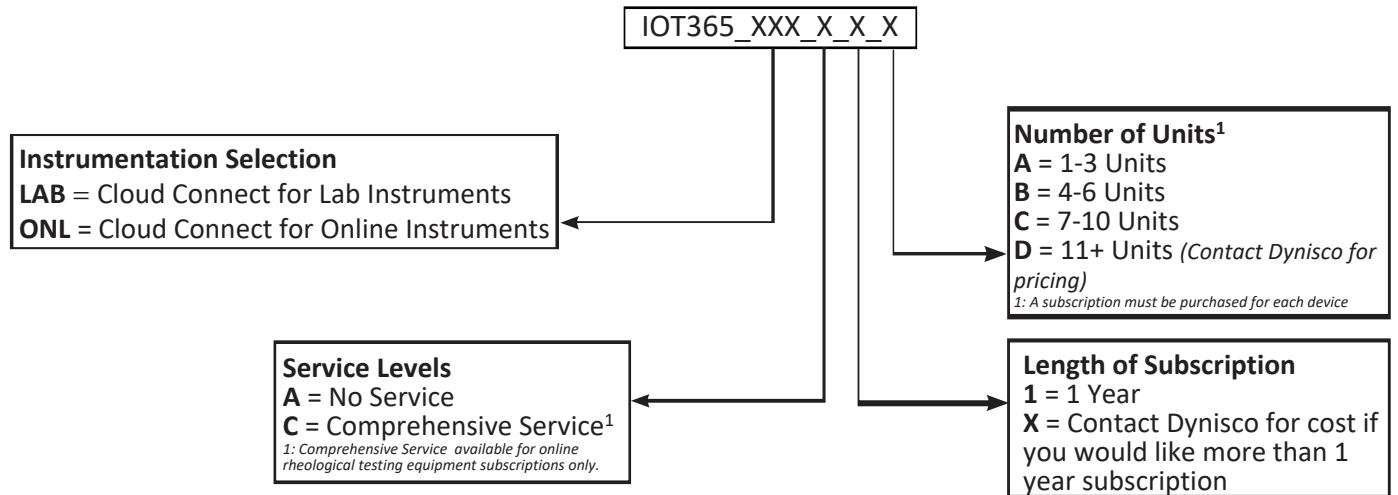

Comprehensive Service Level Offering Includes:

- Full access to Dynisco's IoT Cloud portal with advanced dashboards for full lot process information, lab and production correlations metrics
- (1) One on site 3 day visit for operator equipment and correlation training at an agreed upon time
 - (Travel Expenses to be Invoiced Separately)
- Technical Call Support
- Software Updates
- (1) Quarterly Melt Flow Index or Capillary Rheometer Sample Correlation Test at Dynisco's Rheology lab
- 15% off all service and spare parts purchased while on contract



Azurr-Technology, s.r.o.

Dolní Bečva 579 Tel.: +420 571 647 228
 756 55 Tel.: +420 571 647 310
 Česká republika Email: info@azurr-tech.cz
 www.azurr-tech.cz



Všechny rozměry jsou uvedeny v palcích (mm), pokud není uvedeno jinak. © 2016.
 Společnost Dynisco si vyhrazuje právo provádět změny bez předchozího upozornění.
 Přístupy k dokumentům jako jsou návody k obsluze a jiné podpůrné dokumenty
 naleznete na www.dynisco.com
 Rev:1216